

WIRELESS MULTI-CRITERIA DETECTOR

The TW-DM-01 Taurus wireless multi-criteria detector is the latest in wireless multi-criteria detector technology. The detector is a fully intelligent device combining both smoke and heat detection technologies for improved performance, whilst maintaining high levels of unwanted alarm rejection. Utilising well-proven adaptive radio signal processing algorithms ensure the highest levels of life safety and system reliability are achieved. An in-built magnet test allows easy activation to verify correct functionality and response.



KEY FEATURES

- Advanced dual optical chamber design
- Twin alarm LEDs for 360° visibility
- Multiple operating settings
- Advanced drift compensation
- Bi-directional wireless communication
- Can be used with Taurus addressable and conventional translators
- 22 pairs of field channels
- Long communication range ($\cong 1$ km in open air)
- Dual channel redundancy
- 10 year battery life
- Utilises standard low cost lithium battery technology
- Device identification tab
- Security screw to prevent tampering and unwanted removal
- Easy scan & link programming option
- 3rd party approved
- 5 year product warranty
- Tri-coloured LED

TECHNICAL INFORMATION

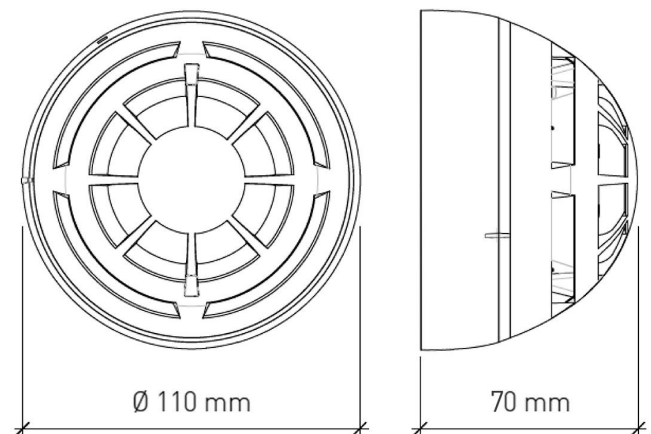

TECHNICAL SPECIFICATION

Operating frequency range	868 – 870 MHz
Max radiated power	14dBm (25mW)
Dimensions	110mm x 70mm
Weight (without batteries)	155 g
Batteries	2x CR123A
Operating Temperature	-10°C to +55°C
Max humidity (non condensing)	95% RH
IP rating	40

STANDARDS & APPROVALS

- EN54-5 Class A1R: Heat Detectors
- EN54-7 Smoke Detectors
- EN54-25: Components using radio links



0051

BASE COMPATIBILITY

This device is supplied with a standard base and is compatible with the following Argus base sounders:

- TW-BS-01 Wireless Sounder Base
- TW-BSB23W-01 Wireless Sounder Bases+ beacon white light (EN-54 23 approved)
- TW-BSB-23R-01 Wireless Sounder Bases+ beacon red light (EN-54 23 approved)

ORDER CODE

TW-DM-01

TAURUS WIRELESS MULTI-CRITERIA DETECTOR

[Check if this document is up to date](#)

Argus Security Srl, Via del Canneto, 14, 34015 Muggia, (TS), Italia **T:** +39-040.23.96.411, **E:** info@argussecurity.it, **W:** www.argussecurity.it

As our policy is one of constant product improvement the right is therefore reserved to modify product specifications without prior notice.